

PRO WEIGH Loadcell guide: Selection, Installation & Testing.

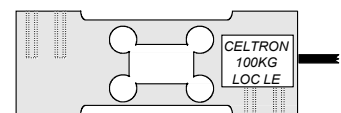
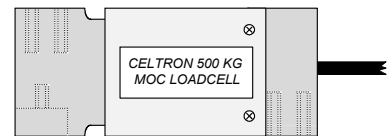
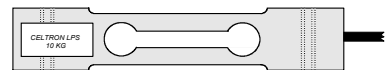
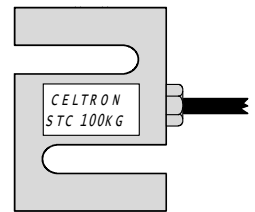
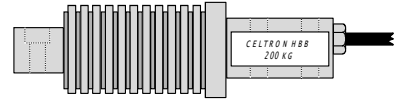

13887-15

© COPYRIGHT 2001 by Pro Weigh Ltd.
PO. Box 35098, Browns Bay, Auckland, New Zealand.
9/25 Airborne Rd Albany, Auckland, New Zealand
Telephone +64-9-415 6500.
Facsimile +64-9-415 6556
Email: craig@proweigh.co.nz.

Contents

Contents	3
Introduction.....	5
General.....	5
About Loadcells.....	5
History	6
Types of Loadcell	7
S Type Loadcell	7
Compression Loadcells.....	7
Shear-Beam	8
Bending-Beam	8
Double Ended Shear.....	9
Single Point	9
Connections.....	11
Mounting Single Point Loadcells.....	13
Positioning The Loadcell.....	13
Mounting The Loadcell.....	14
Overload Stops	14
Accuracy.....	14
Overload Stops	17
Making Overload Stops.....	17
Setting Overload Stops	18
Testing Loadcells	21
Physical Condition.....	21
Electrical Tests	21
Bridge Resistance.....	21
Leakage Resistance	22
Zero Balance.....	23
Other Information	23

Introduction

General

This guide has been produced due to considerable demand from Technicians and Engineers who need to understand how loadcells work, how to perform a quick check to test loadcell integrity, and how to make mechanical overload stops to protect loadcells. There is also a small section on mounting single point loadcells as these are a very popular model of loadcell.

These topics represent the most common questions asked of *Pro Weigh* Engineers regarding loadcells. This guide also intended to be of assistance to engineers not familiar with loadcell technology, to set up their loadcells for optimum performance.

This document is a general guide only. It is in no way intended to be an absolute reference on loadcells.

About Loadcells

Loadcells are transducers that measure mechanical force and output a linear change in voltage proportional to that force. Loadcells are rated in units of weight ie grams, kilograms and tonnes (or pounds in the case of American-made loadcells).

A loadcell will measure from zero to the stated capacity. The accuracy of the loadcell is generally stated as a percentage of the overall capacity.

For example, if a 100kg loadcell has an overall accuracy of $\pm 0.03\%$, then that loadcell will measure weight from zero to 100kg to a worst case accuracy of ± 30 grams. This applies whether it is weighing a load of 5kg or 95kg.

A loadcell data sheet will provide other important information about the loadcell. Usually included is:

- **Capacity:** The overall capacity of the loadcell.
- **Overload:** The maximum percentage of full load that the loadcell can handle before damage occurs. (This is typically 150%)
- **Accuracy:** This may be expressed in terms of linearity, hysteresis, repeatability, creep and so on. These figures are all expressed as a percentage of the overall capacity of the loadcell. For example, a 100 kg loadcell has an overall accuracy figure of $\pm 0.03\%$. This means that the loadcell will measure loads between 0 and 100 kgs to ± 30 grams, whether it is measuring a load of 5 kg or 95 kg.
- **Sensitivity:** The sensitivity of the loadcell determines the actual voltage output you will get when you place the full load on the loadcell. These figures are all expressed in mV/V. If the loadcell has a 3mV/V output, and the excitation voltage is 10 Vdc, then the output from the loadcell at full load will be 30mV.
- **Thermal Sensitivity:** This tells you how much the output will change with change in temperature. It is usually expressed in percent of full load/ $^{\circ}\text{C}$.
- **Platform Size:** For single point (sometimes called off-centre or platform loadcells) this tells you the maximum platform size that may be arranged over the loadcell.

Loadcells Are Not Strain Gauges. Strain gauges are the small sensors that are glued to the loadcell body. When the loadcell body is put under mechanical strain, the strain gauges are stretched. When they stretch they change resistance. The strain gauges are arranged in a bridge circuit with other resistors and usually temperature compensation gauges. When the circuit is excited with a voltage, any change in the strain gauge resistance corresponds with a change in the output voltage.

The body of the loadcell (usually steel, stainless steel or aluminium) is machined to ensure that the section where the strain gauges are mounted is put under the most mechanical strain.

History

Strain gauges were invented in 1938 by two very clever guys; Dr Arthur C Ruge of MIT and E Simmons of Cal Tech.

Strain gauges themselves consist of thin wire or foil elements that are glued to the loadcell body. Strain gauges are cunningly shaped so that even very small movements or “stretching” of the gauge results in comparatively large changes in resistance.

The relationship between strain and change in resistance is almost perfectly linear. Accuracies of $\pm 0.01\%$ are not uncommon for a high accuracy loadcell.

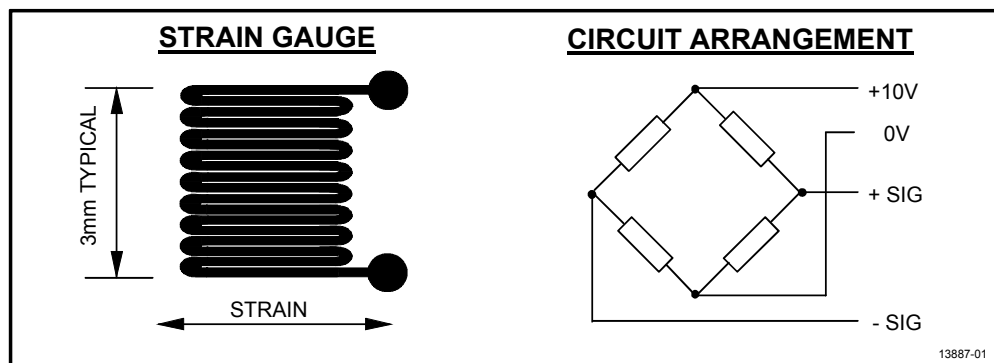

Types of Loadcell

Again this is not a comprehensive guide to every loadcell known to man, rather a brief overview of what is available to the New Zealand market. Most of these loadcells are stocked by *Pro Weigh Ltd.*

S Type Loadcell

The S Type Loadcell is most commonly used in tension (but can be used in compression).

The S Type Loadcell must be arranged so that the force applied passes perpendicularly through the centre of the loadcell. To ensure this happens, most end users fit clevis pins or rod-end bearings to the loadcell to movement which copes with expansion forces and other miss-alignment. S Type Loadcells are used for vessel weighing, tensile testers, torque restraints and other applications. S Type Loadcells are available in capacities from 20kg to 10,000kg.

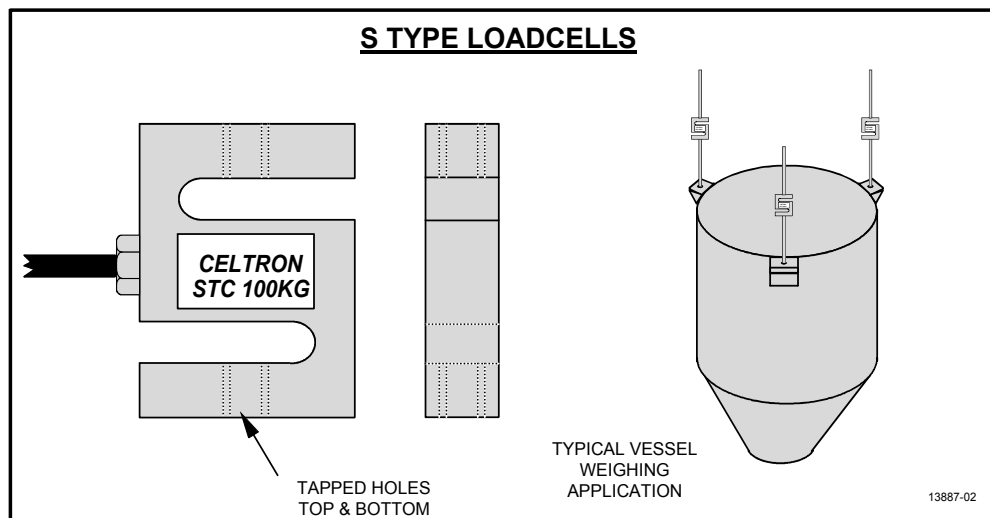

Compression Loadcells

Compression Loadcells come in a wide variety of shapes and accuracies. Generally the low profile "hockey puck" type offer low accuracy, while "can" or "cylinder" types offer higher accuracy. They are all generally fitted with a hardened, rounded button to which the load is applied. They are often used in test rigs, and vessel weighing.

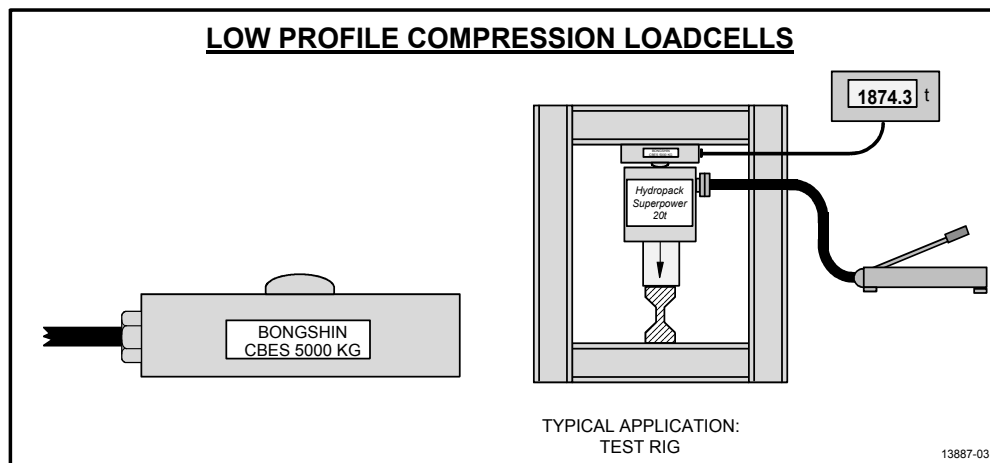

Shear-Beam

This loadcell is bolted to a fixed structure at one end and force is applied through a single point at the other end, causing the beam to bend and placing the strain gauge area under shear. Shear beams are most commonly used in conjunction with special swivel feet and mounted in the corners of large platform scales. They are also used for vessel weighing either in tension, or built into special loadcell mounts in compression. Shear-beam loadcells are generally very accurate and come in capacities from 100kg to 10,000kg.

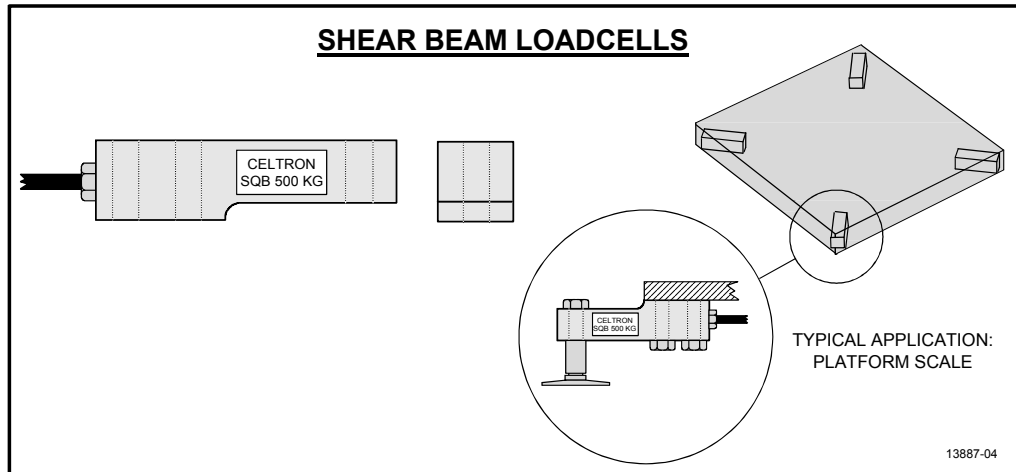

Bending-Beam

Used in similar applications to the shear beam, the bending beam is generally a more accurate loadcell, and available in lower capacities. The most common type available is the all stainless steel "bellows version" which is generally sealed to a very high integrity (IP 67 or 68). This makes them extremely suitable for wash-down situations and sanitary environments such as dairies and food processing plants. Bending beams are used in platform scales, weighing small hoppers, belt weighers and weighfeeders and other high precision applications. Capacities range from around 5kg to 1,000kg. Accuracies can be as good as $\pm 0.007\%$.

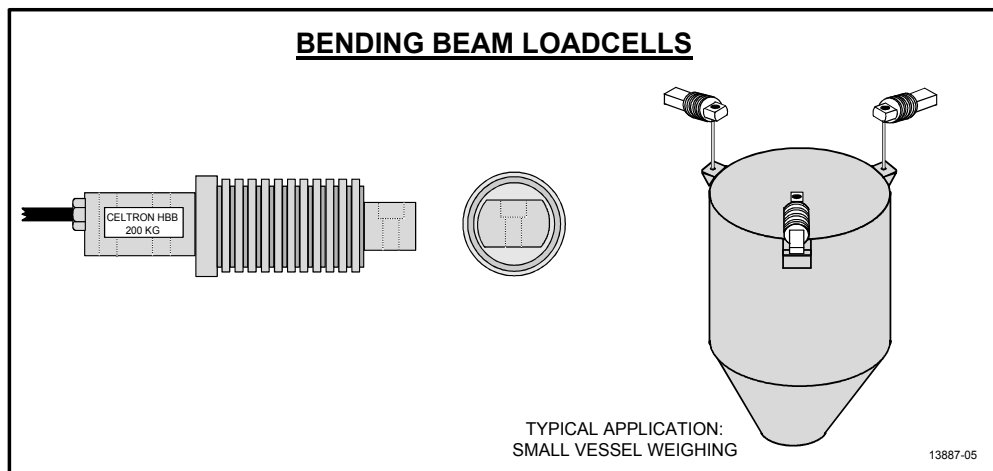

Double Ended Shear

The double ended shear beam was designed almost exclusively for vessel weighing and weighbridges. The double ended shear beam is a fairly recent development in loadcells and offers high accuracy weighing combined with rugged built-in restraints and excellent rejection of side-force errors. The double ended shear is always used in a loadcell mount. Capacities range from 500kg to 50,000kg.

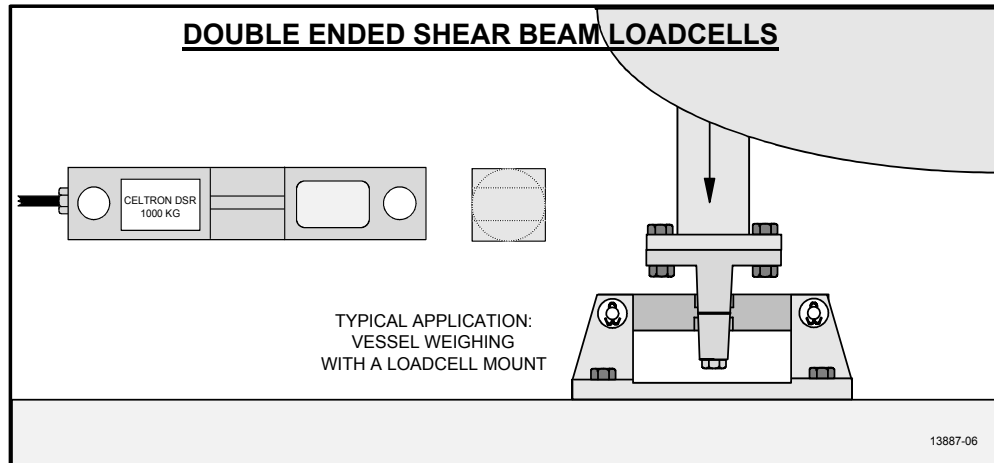

Single Point

Single Point Loadcells probably account for the largest percentage of all loadcells in existence world wide. They are the heart of most small bench-top scales and are also used in a wide range of other applications. “Single Point” is really a bad name for these loadcells. “Platform” loadcells would be far more applicable, but for some reason they are known as “single point” loadcells.

What makes them different from all the loadcells discussed so far, is that the load does not need to be applied through a single mounting point on the loadcell. Instead, a single point loadcell will accept a platform of specified dimensions that can be bolted directly to the loadcell. The load can then be applied to any point on that platform and the loadcell will measure it accurately. Capacities range from around 600 grams up to 2,000kg.

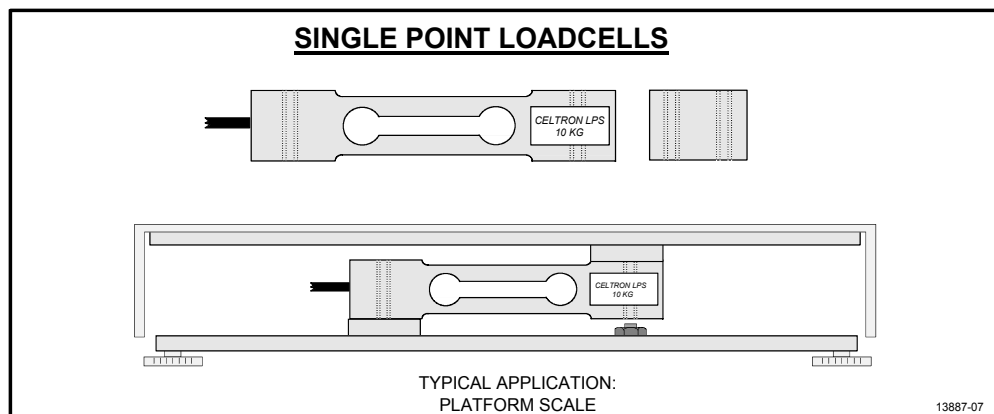

Connections

Loadcells have either 4-wire or 6-wire screened cables connected to them. The 4-wire connection has 2 excitation wires and 2 signal wires. Very simply : you connect the 2 excitation wires to a stable DC supply, and measure the output on the 2 signal wires.

NOTE: As all *Pro Weigh* controllers, indicators and transmitters use a DC excitation voltage, only DC excitation will be mentioned in this manual. Some indicators and controllers use an AC excitation. This is not covered here.

With a 6-wire connection, the 2 extra wires are called “sense” wires. If the controller has separate terminals for sense, these wires should be connected to those terminals. If it doesn't, then the sense wires should be connected to the excitation terminals. The sense wires are used to measure the exact excitation voltage at the loadcell. If there is a long cable run, this voltage can be less than the voltage at the excitation terminals on the controller. Because the sense wires do not carry a large current, voltage drop is minimal, and therefore they allow the controller to “sense” the actual voltage at the loadcell and compensate for the voltage drop when it converts the signal voltage into a digital display.

Following are some points and tips with loadcell wiring and a table showing colour codes for *Pro Weigh* loadcells.

- Reverse connection of polarity or excitation/signal wires will not harm the loadcell, and generally not the loadcell controller/indicator.

- Always use shielded cable when connecting to loadcells. Be sure to follow the loadcell processor instructions as to where to connect the shield wire.

- Run the loadcell cable separate to mains voltage cables or high current cables. Loadcell input signals are very susceptible to interference which can come from relays, contacting motors, motor controllers and so on.

- Do not cut the loadcell cable, especially when using multiple loadcells, as this changes the resistance characteristics of the individual loadcell. Coil up excess cable and clip it neatly away.

- When splicing cables, preferably use a junction box, or resin sealed shrink joints.

- With multiple loadcell installations, use one junction box to link the loadcells and run one cable between the junction box and the controller.

- Earth the cable shield at one end only. Earthing at both ends can create “earth loops”

- Use the “drip loops” at the loadcell and to help prevent water ingress to the loadcell.

LOADCELL CONNECTIONS: CABLE COLOUR CODES					
	HBM	Celtron LPS & Celtron MBB	All other Celtron	PT	Tanaka, UWE & Minabea
Excitation +ve	Blue	Red	Red	Red	Red
Excitation -ve	Black	Blue	Black	Black	White
Signal +ve	White	Green	Green	Green	Green
Signal -ve	Red	White	White	White	Blue
Sense +ve	Green			Brown	
Sense -ve	Grey			Blue	
Screen	Silver	Silver	Silver	Yellow / silver	Yellow / silver

Mounting Single Point Loadcells

Single point loadcells are one of the easiest types of loadcells to install. There are still several points to be aware of however and EMC have come across a few home-made disasters that do not work.

Positioning The Loadcell

The platform size of a single point loadcell is taken around the centre point of the loadcell not the centre point of the mounting foot of the loadcell. For example, a platform is being made up using a Celtron LOC 100kg loadcell with a platform size of 400mm by 600mm. The loadcell would be arranged as in the drawing below.

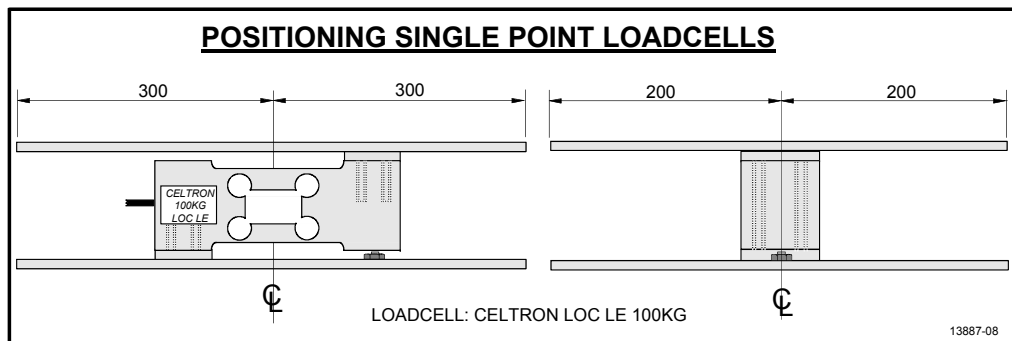

For small weigh hoppers, use the centre of gravity of the hopper as a platform edge. (See drawing below; in this case a Celtron LPS 10kg single point loadcell is shown. These loadcells have a platform size of 300mm by 300mm.).

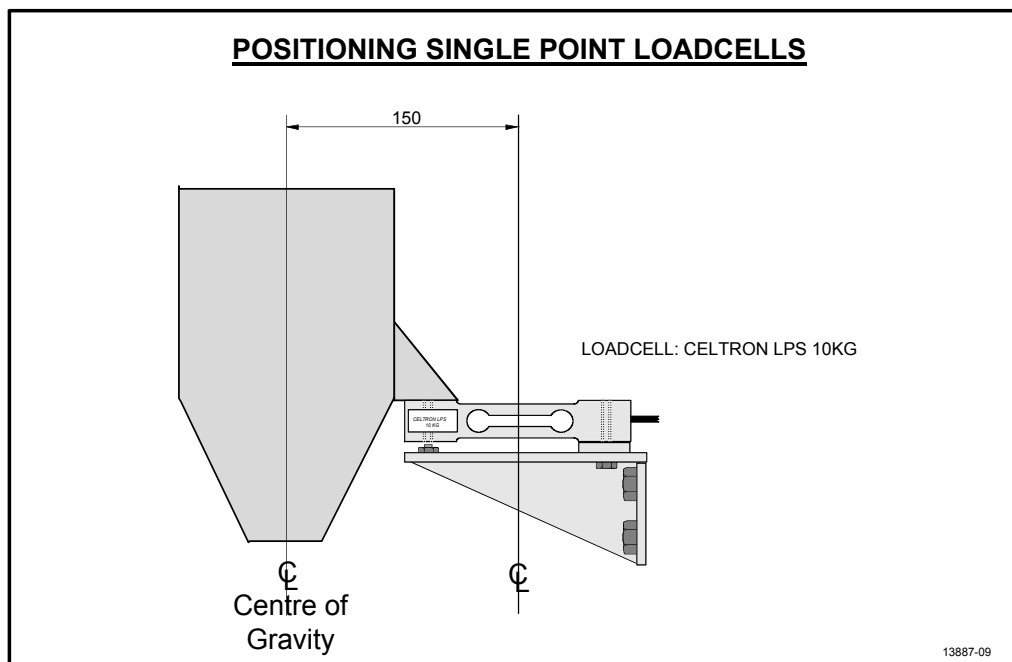

Mounting The Loadcell

On all single point loadcells there is a clearly defined mounting pad. The mounting structure must not protrude past this area in to the centre of the loadcell (see drawing).

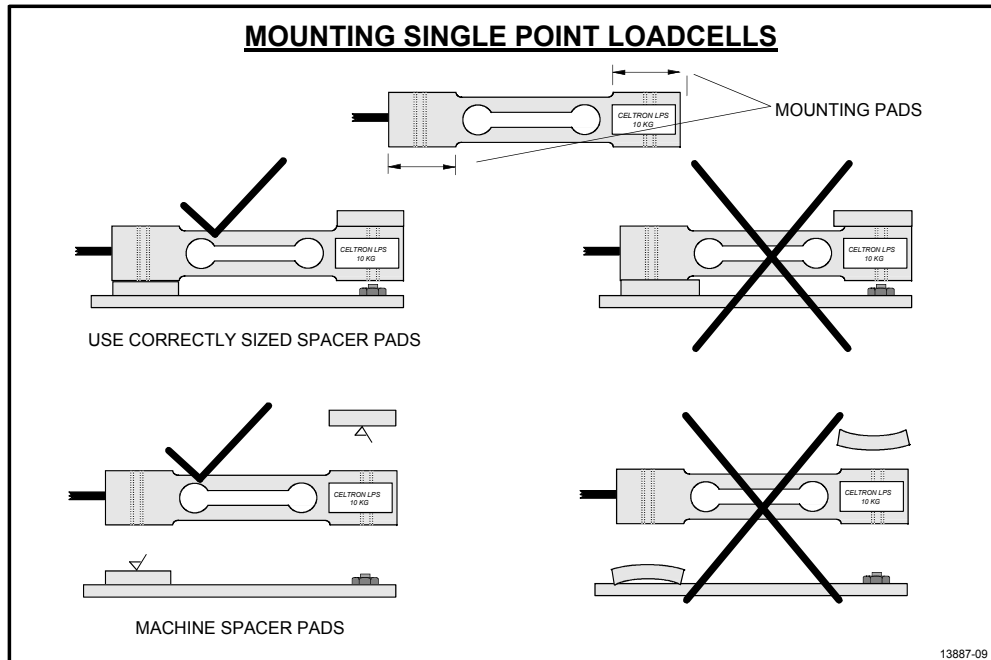

The spacer or pad that the loadcell is mounted to must lift the loadcell clear of the surrounding structure. Usually 5mm would be the minimum spacer thickness. The spacer or pad **must be flat, preferably machined**. If the pad is not flat, the loadcell will be distorted when it is bolted up.

Overload Stops

At a bare minimum, the loadcell should have a mechanical overload stop installed directly under the loadcell. The best set-up is to have platform corner overload stop as well. (See the next section on how to set overload stops).

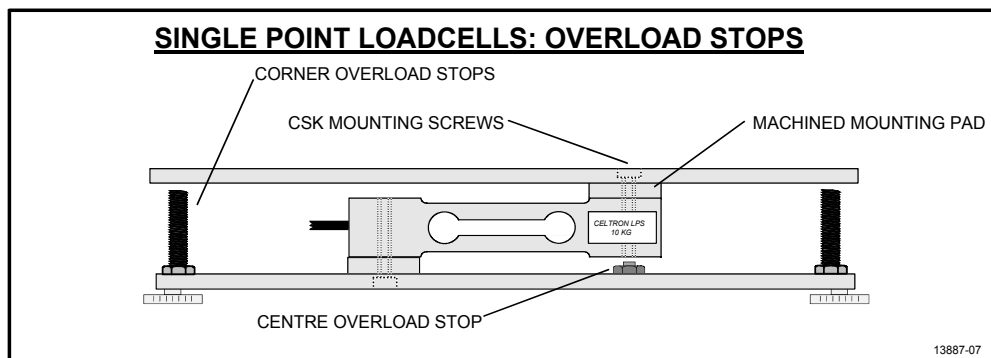

Overload stops must be at least 10mm diameter. They should preferably be a fine thread and **MUST** have a machined flat face on the overload stop. Some loadcells (Celtron MOC and HOC) come complete with tapped recesses specifically for overload stops.

Accuracy

Because all the weight is being transferred directly to the loadcell and there is no interaction between multiple loadcells, the accuracy of single point loadcell installations is excellent.

Generally absolute accuracy to the limit of the loadcell accuracy (typically $\pm 0.02\%$) is achievable. Often repetition to greater accuracies is also achievable. This makes the single point loadcell a very versatile transducer and accounts for its ever increasing popularity.

Overload Stops

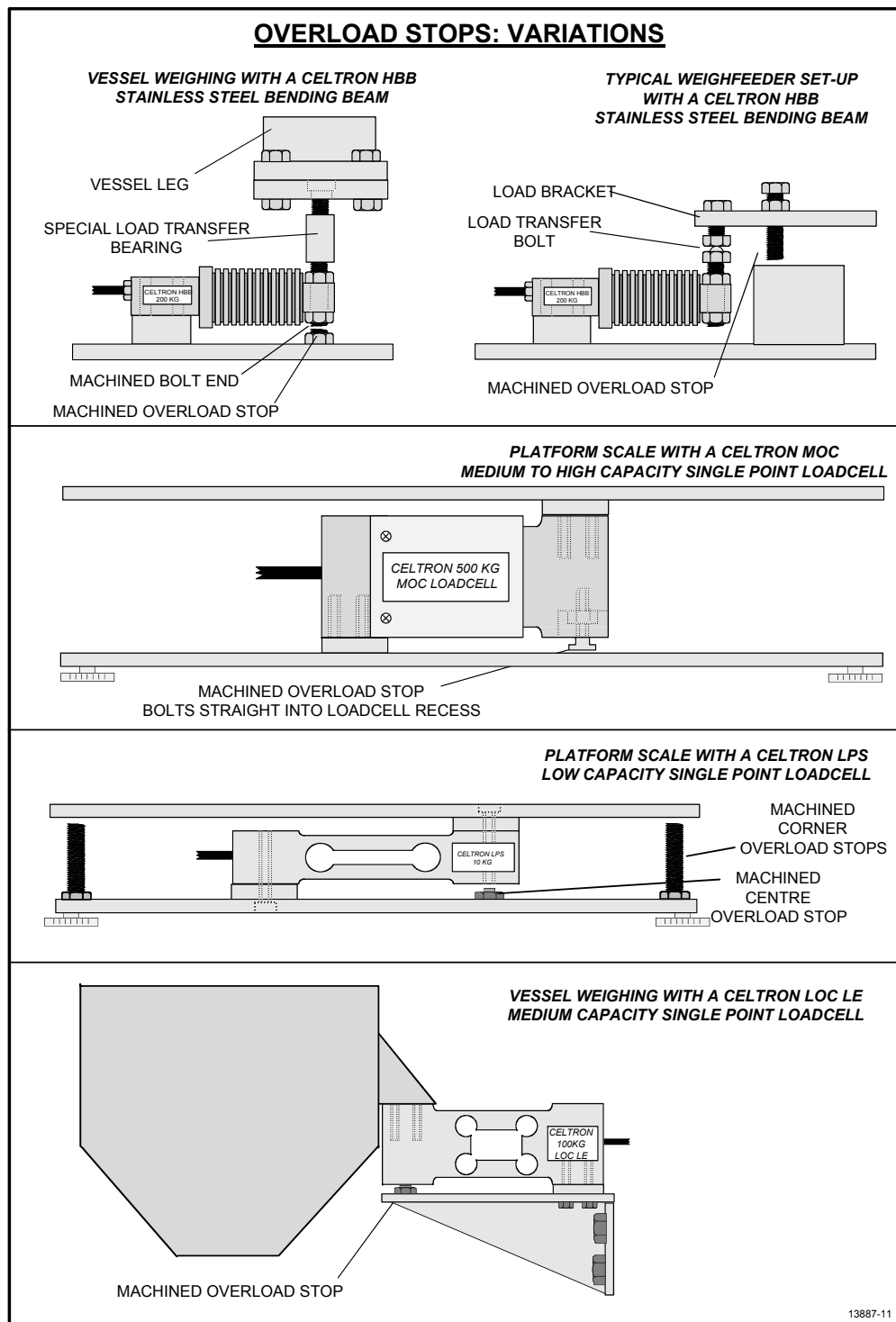

Making Overload Stops

Most bending beam and single point loadcells can be fitted with mechanical overload stops which will generally protect them from all but the most severe overloading.

Shear beam, compression, S type and double ended shear loadcells are not suitable for overload stop protection. This is because they do not bend enough to allow a big enough gap between the loadcell and the stop.

The various different methods of mounting overload stops for different styles of loadcells are shown on the previous page. In all cases machined stops must be used.

Setting Overload Stops

There is only one way to set a loadcells overload stops accurately. That is to measure the loadcells output while setting the stop. (Put away those feeler gauges, shims & cigarette papers and dial test indicators).

The following equipment is required to set a loadcells overload stop.

- An accurate multimeter with a mV range.
- A DC source to power the loadcell. This may be the loadcell indicator, a dc power supply or a 12 volt battery.
- A controlled method to apply force to the loadcell. A G-clamp is ideal.
- The loadcell data sheet with the loadcells sensitivity stated.

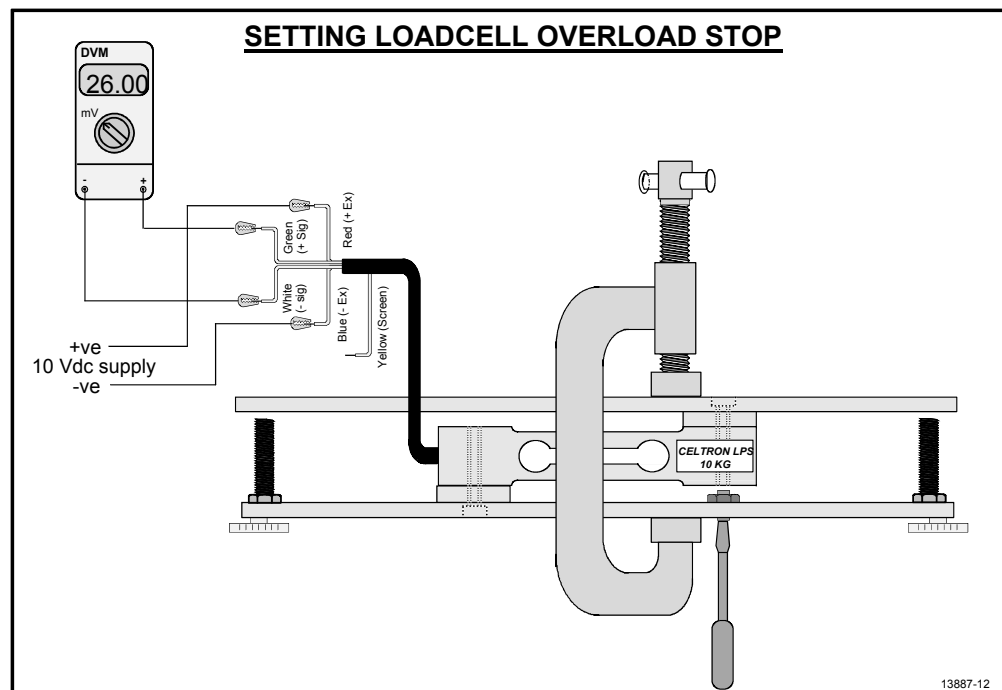

The following procedure will take you step-by-step through the overload stop setting procedure:

- 1 Wind the overload stop well clear of the loadcell or bracket.
- 2 Connect the excitation leads of the loadcell to a known dc power supply.
- 3 Calculate the loadcell output in millivolts at 100% load. eg: If the DC power supply is 10 volts and the loadcell sensitivity 2mV/V, at 100% load the loadcell output will be 20mV.
- 4 Multiplying the 100% load output by 1.3. This is the output you will set the stop at (as the loadcell can withstand 150% overload, 130% is a safe figure to set the stop at).
- 5 Connect your multimeter to the output of the loadcell. Ensure the range is set to mV.

- 6 Apply force carefully to the loadcell. For small loadcells this may be done by hand, but for larger loadcells and for better control, some type of clamp, screw jack or hydraulic jack may be used.
- 7 While applying force keep a careful watch on the multimeter display. **It is very easy to damage the loadcell by applying too much force.** When the output reaches 130% (in the previous example this would be 26mV) **STOP** applying force.
- 8 Adjust the overload stop until it just bottoms out.
- 9 Lock the overload stop locknut.
- 10 Release the force and re-apply. The output should not be capable of exceeding 130%. If it does repeat the adjustment process.

Testing Loadcells

Physical Condition

- Firstly check the loadcell for signs of physical damage.
- Is the loadcell surface badly rusted or corroded?
- Have the strain gauge areas become compromised?
- Is there any physical damage to the loadcell? Is the body bent or twisted? (With single point loadcell, use a steel rule to check the body for straightness).
- What is the condition of the loadcell cable? Does it have any cuts, splits or tears?

If the answer to any of the above is YES, there is a good chance the loadcell is faulty. Proceed with the electrical checks.

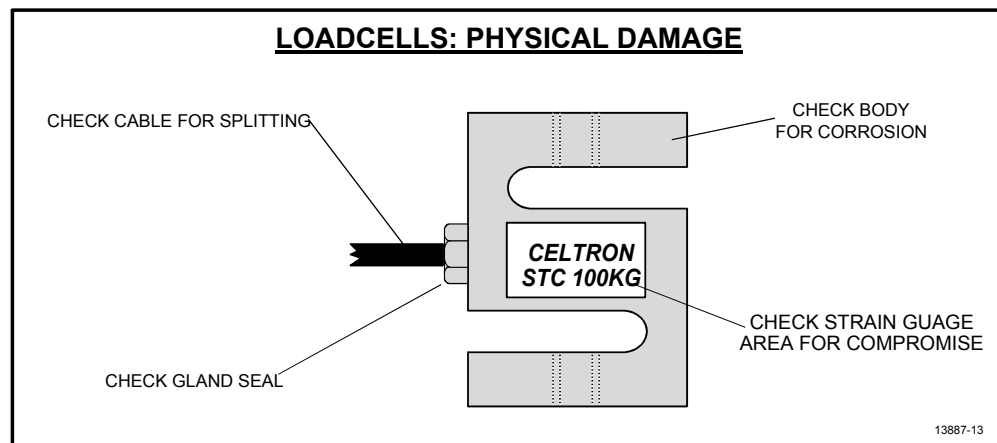

Electrical Tests

For these tests you will need an accurate 3½ digit (or better) multimeter with a low voltage Mega-Ohm range and a millivolt range. You will also need a DC source to excite the loadcell - a 12V battery the weight indicator or a DC power supply will do. You will also need to obtain a data sheet for the model of loadcell you are testing.

The chart below lists the colour codes for most *Pro Weigh* supplied loadcells.

LOADCELL CONNECTIONS: CABLE COLOUR CODES					
	HBM	Celtron LPS & Celtron MBB	All other Celtron	PT	Tanaka, UWE & Minabea
Excitation +ve	Blue	Red	Red	Red	Red
Excitation -ve	Black	Blue	Black	Black	White
Signal +ve	White	Green	Green	Green	Green
Signal -ve	Red	White	White	White	Blue
Sense +ve	Green			Brown	
Sense -ve	Grey			Blue	
Screen	Silver	Silver	Silver	Yellow / silver	Yellow / silver

Bridge Resistance

Obtain the data sheet which provides input and output resistances for the loadcell you are checking. Switch your multimeter to the ohm range and measure the input resistance (across the excitation wires). Next measure the output resistance (across the signal wires) compare these values to the data sheet. They should be within the tolerance stated. If they are different, the loadcell has been damaged and will require replacement. Typical values for input and output resistance are 350Ω and 700Ω .

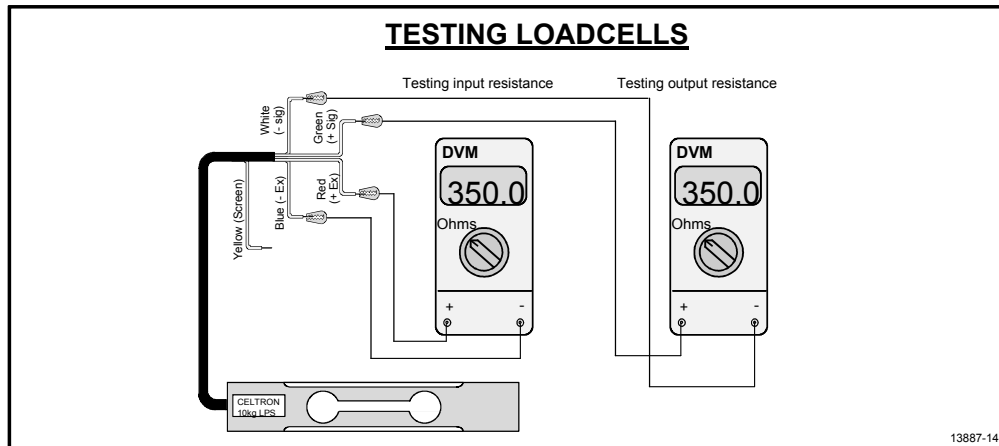

Leakage Resistance

Set your multimeter to ohms and measure from each of the loadcell wires (4 or 6 wires) to the loadcell cable screen. Next measure from each loadcell wire to the loadcell body. These readings should be greater than $1000m\Omega$. (This may read OL on some meters). If a reading of less than $1000m\Omega$ is encountered, then the loadcell has "leakage" between the internal circuit and the loadcell body or cable screen. This is usually caused by moisture ingress to the loadcell body or cable. Sometimes the cable can be repaired, but if the loadcell has moisture in it, it usually requires replacement.

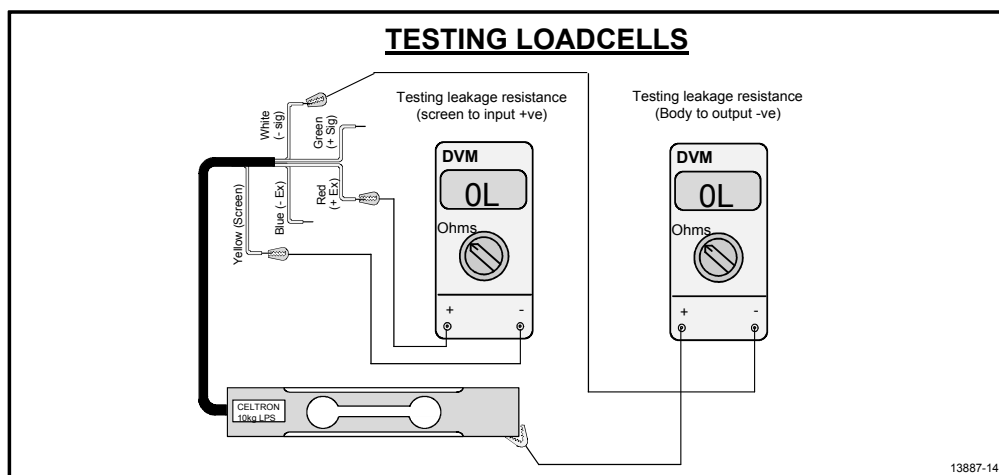

Zero Balance

This test checks for mechanical overload, where the body of the loadcell has been stretched beyond its elastic limit. This is a common cause of loadcell failure especially in low capacity loadcells (100kg or less).

Connect the loadcell to a stable DC source of between 5 and 15 volts. Switch the multimeter to mV and connect to the loadcell signal wires. The meter should read 0.00mV \pm approximately 1% of full load. Small overloads can generally be tolerated although they may effect the linearity of the loadcell. If the output reads greater than $\pm 10\%$ of full scale, then the loadcell will require replacement. This indicates severe overload.

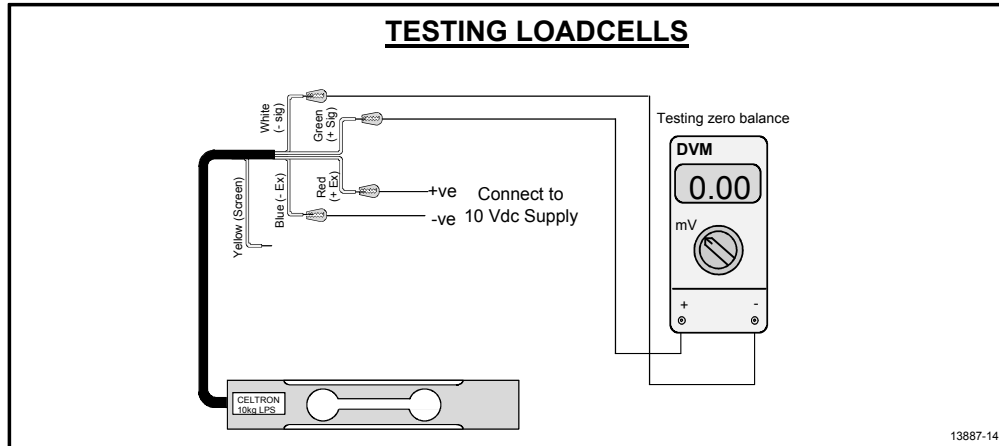

Other Information

Pro Weigh hope that this guide has been helpful to you. Another *Pro Weigh* guide that may be of help is the [**Pro Weigh Vessel Weighing Manual**](#). This deals specifically with Vessel Weighing and Loadcell mounts, from sizing the loadcells, through mounting the loadcells to calibration of the weighing system.

For specific information on *Pro Weigh* Processors and weight indicators, refer to the Manual for that processor. These manuals are available from *Pro Weigh*.

For individual assistance, please contact *Pro Weigh Ltd* directly.

Pro Weigh Ltd accept no responsibility for loadcell failures occurring after loadcells have been set up using this guide.

PRO WEIGH LIMITED

P O Box: 35098 Browns Bay, Auckland

Phone: 09 415 6500

Fax: 09 415 6556

Email: craig@proweigh.co.nz